



# SELECT Synchro

Transform Your Selective Soldering Process

The SELECT Synchro™ is a selective soldering system designed for high-volume through-hole and mixed-technology surface mount soldering applications and maximum throughput. The system simultaneously processes up to seven printed circuit boards with its highly flexible configuration and compact footprint. Process boards up to 2500 mm long and up to 460 mm wide with the standard Synchro system and up to 680 mm wide with the Synchro XL.

**Versatility.** The Synchro system easily flexes to support various soldering applications, including single-sided, double-sided through-hole, or mixed technology surface mount and through-hole assemblies. The system configuration includes a Microdrop drop-jet fluxer and can accommodate up to five solder nozzles to apply lead-free and leaded alloys. Various options provide added flexibility.

**Value.** With a reputation for innovation, Nordson SELECT process solutions deliver a maximum return on investment and low cost of ownership. From initial process development through full-scale production, you have the support of our experienced worldwide engineering, applications development, and technical service network.

## Benefits

- Boards continuously travel through the system, boosting throughput by 20-40% for most applications, with more gain possible if conveyance and soldering times are comparable.
- Soldering work is automatically balanced between soldering pots to increase throughput further.
- Due to the minimal pot and fluxer motion in the conveyor direction, the system footprint is reduced by 60% compared to traditional multi-station soldering machines.
- Process up to seven printed circuit boards simultaneously using different alloys and nozzles or one fixed nozzle for all your products.
- Supports five solder pots, each with the ability to accommodate different nozzle sizes, eliminating the need to change nozzles.

## Standard Features

Seven operations with independent areas for concurrent fluxing, preheating, and soldering

Five individual solder pots

SMEMA conveyor with positive board location

Automatic conveyor width adjustment

Microdrop drop-jet fluxer

Flux-level sensing system

All titanium solder pot and pump assembly

Quick-change magnetically-coupled solder nozzle

SolderWorks Editor and machine control software:

- Easy “point-and-click” programming
- Remote machine control
- Remote machine maintenance
- Network capability

## Options

Fully-automated fiducial alignment and board mapping

In-process, closed-loop flux verification system for drop-jet control

Full surface topside infrared preheating

Full surface bottom-side infrared preheating

Closed-loop pyrometer control

Board warpage sensing system

Process viewing camera and second monitor

Automatic solder wire feeding system

Automatic solder level sensing system

Wave-height-control sensing system

Automatic solder nozzle cleaning system

Data logging system with traceability for all process parameters, barcode reader

Automatic wave-height monitoring

MES capability

# SELECT Synchro™

## Specifications

<b>Motion System</b>	Z Accuracy	±100 µm (0.004 in.)
	Z Repeatability <sup>1</sup>	±50 µm (0.002 in.), 3 sigma
	Z Velocity	0.05 m/s peak (2 in./s)
	X-Y Accuracy	±100 µm (0.004 in.)
	X-Y Repeatability <sup>1</sup>	±50 µm (0.002 in.), 3 sigma
	X-Y Velocity	0.2 m/s peak (8 in./s)
<b>Computer</b>	PC with Windows® operating system	
<b>Software</b>	SolderWorks Editor “point-and-click” programming and machine control software	
<b>Solder Pot Capacity and Weight</b>	Capacity <sup>2</sup>	Approximately 12.0 kg (26.4 lbs.)
	Total weight of tin-lead solder, solder pot, and pump assembly <sup>2</sup>	Approximately 22.4 kg (49.2 lbs.)
	Total weight of lead-free solder, solder pot, and pump assembly <sup>2</sup>	Approximately 19.7 kg (43.3 lbs.)
	Maximum temperature	320°C (608°F)
<b>Solderable Area (X-Y)</b>	SELECT Synchro standard: maximum 460 mm x 2500 mm	
	SELECT Synchro XL: maximum 680 mm x 2500 mm	
	Minimum 50 mm x 100 mm	
<b>Preheating</b>	Selectable topside preheating from 1.5 kW to 24.0 kW	
	Selectable bottom preheating from 1.5 kW to 9.0 kW	
<b>Board Handling Capability</b>	Maximum board size <sup>3</sup>	SELECT Synchro standard: 460 mm x 2500 mm SELECT Synchro XL: 680 mm x 2500 mm
	Minimum board size <sup>3</sup>	50 mm x 100 mm
<b>Conveyor</b>	Minimum/maximum board and carrier thickness <sup>4</sup>	0.5 mm to 5 mm
	Maximum overboard clearance	120 mm
	Maximum underboard clearance	40 mm (80 mm is optional)
	Edge clearance <sup>5</sup>	3 mm (0.12 in.), edge conveyor including on-rail clamps
	Transport height <sup>6</sup>	Conforms to SMEMA standard for conveyor height; height adjustable from 940-965 mm from floor to bottom of board
	Load capacity <sup>7</sup>	Standard conveyor: Max. 10 kg for 500 mm; 3 mm board seating Heavy-duty conveyor: Max. 20 kg for 500 mm; 5 mm board seating
	Operation modes	Automatic (SMEMA), manual or pass-through
<b>Facilities Requirements</b>	System footprint	SELECT Synchro standard: 2500 mm x 1500 mm SELECT Synchro XL: 2500 mm x 1750 mm
	Compressed air	6 bar minimum, 8 bar maximum
	Power (mains) <sup>8</sup>	400/480VAC, 50-60 Hz, three phase, 50 kW, 72 A
	Nitrogen	99.99% (4.0) pure, 4-6 bar, 1.3m <sup>3</sup> /hour (single pot), 6.5 m <sup>3</sup> /hour (5 solder pots)
	Ventilation	Rear 300 m <sup>3</sup> /hour, two 100 mm diameter ducts
	System weight <sup>9,10</sup>	SELECT Synchro standard: 1800 kg SELECT Synchro XL: 2000 kg

### Footnotes

1. Repeatability is measured at full rated system speed.
2. Solder capacity and total weight of solder pot and pump assembly varies depending on solder alloy.
3. Board size is reduced when operating in parallel or double modes.
4. Contact factory regarding smaller or larger boards/carriers.
5. Edge conveyor conforms to SMEMA standards.
6. 900 mm (35.4 in.) non-SMEMA conveyor height available upon request.
7. Total weight of all parts on conveyor at any one time. Contact factory regarding requirements for greater load capacity.
8. Electrical power varies depending on configuration.
9. System weight varies depending on configuration.
10. Other configurations may be available. Contact Nordson Electronic Solutions.

Windows is a registered trademark of Microsoft Corporation in the United States and other countries.  
Additional options may be available: contact Nordson Electronics Solutions for further information.

# SELECT Synchro™

## System Dimensions

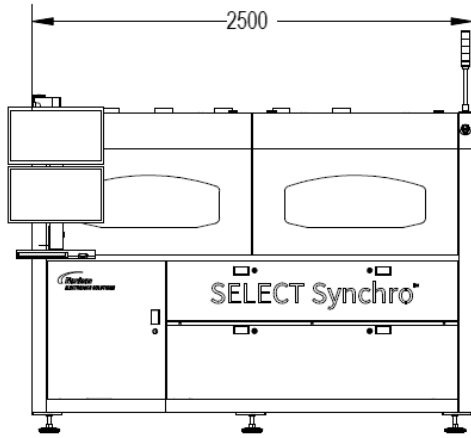

Front view 2500 mm (~8.2 ft.)

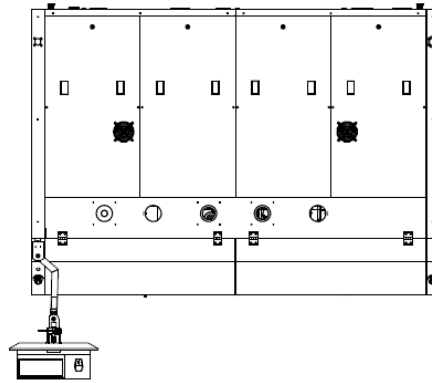

Top view

For more information, visit our website to find your local regional office or representative.

We have several global locations to serve you.

North America  
Asia Pacific  
EMEA

[www.nordson.com/electronics](http://www.nordson.com/electronics)

[info-electronics@nordson.com](mailto:info-electronics@nordson.com)

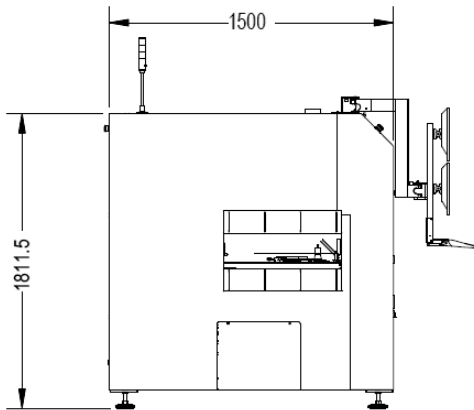

Side view 1500 mm x 1811.5 mm  
(~4.9 ft. x 5.9 ft.)

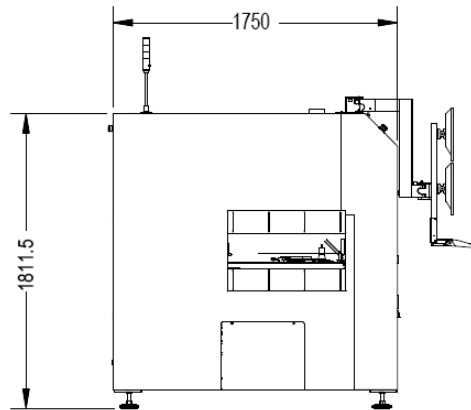

Synchro XL  
Side view 1750 mm x 1811.5 mm  
(~5.7 ft. x 5.9 ft.)



**maxtronix, inc.**

#1 Mon-el St., Mon-el Subd., Dr. A. Santos  
Ave., Brgy. San Antonio, Paranaque City,  
Philippines 1715

Tel: (+632) 8820-6329

Fax: (+632) 8820-4839

Website: [www.maxtronix.net](http://www.maxtronix.net)

**North America Headquarters**  
2747 Loker Avenue West  
Carlsbad, CA 92010-6603, USA

+1.760.431.1919

Published February 2023

**Nordson**  
ELECTRONICS SOLUTIONS